

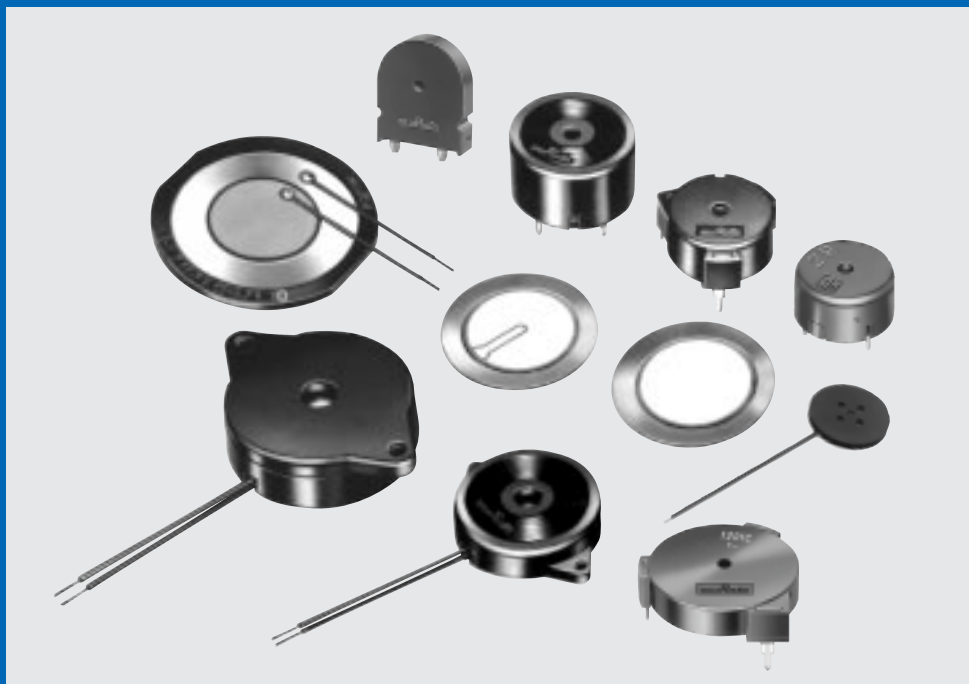

Piezoelectric Sound Components

PIEZOELECTRIC SOUND COMPONENTS



*Innovator
in Electronics*

Murata
Manufacturing Co., Ltd.

Cat.No.P37E-15

INTRODUCTION

Recently, technological innovations are being rapidly introduced in the area of Office Automation (OA) equipment, VCR, and Communication equipment, etc.. The core technologies behind these innovations are multifunction, down-sizing and weight reduction. MURATA, as the leader of technologies for piezoelectric ceramics, has been succeeding to develop various unique products which meet needs in the advanced information society.

The "piezoelectric sound component", which is introduced herein, is also one of MURATA's original products. Piezoelectric sound components are now drawing attention widely as suitable components for various electronic

equipment like as OA equipment (ex. word-processor, typewriter, FAX machine, etc.), audio equipment (ex. radio-cassette, tape recorder, etc.), and telephone sets.

Also, the application range is expanding from a monitor sound for the controller to time signal, alarm, speaker, ringer and receiver for telephone set. So, now piezoelectric sound components are working as an "interface" between human and electrical equipment.

This catalog is providing various types of piezoelectric sound component which could help design of equipments to lead the best solution.

CONTENTS AND APPLICATION MATRIX OF PIEZOELECTRIC SOUND COMPONENTS

		Application																	Page
		Part Number	Tele- phone	Radio Cassette Tweeter	Watch	Clock	Medical Equip- ment	Gas Alarm	Camera	Toy	Bar Code Scanner	Type- Writer	Printer	Word Processor	Compact Disk	Micro- Wave Oven	Air Condi- tioner	Fan Heater	
Piezoelectric Diaphragm	External drive type	7BB-12-9		●	●	●	●		●	●									
		7BB-15-6		●		●	●		●	●									
		7BB-20-3	●	●	●	●	●			●	●								
		7BB-20-6		●		●	●			●	●								
		7BB-27-3	●	●		●	●				●	●							
		7BB-27-3R5	●	●		●	●				●	●							
		7BB-27-4	●	●		●	●				●	●							
		7BB-35-3	●			●					●	●							
	7BB-41-2	●																	
	7BB-50M-1	●																	
	7SB-20-7		●	●	●	●			●										
	7MB-15-11		●																
	7MB-20-7		●		●					●									
	7MB-27-3		●		●					●									
	7MB-27-4		●		●					●									
	7NB-31R2-19R7DM-1	●																	
7SB-20-7A1		●						●											
Self drive type	7BB-20-6C	●						●	●										
	7BB-27-3C	●					●		●										
	7BB-27-4C	●					●		●	●									
	7BB-35-3C	●					●			●									
	7BB-41-2C	●																	
	7SB-34R7-3C						●												
	7NB-27-2C	●																	
	7NB-27-3C	●						●											
7NB-27-4C	●						●												
Piezoelectric Sounder	External drive type	PKM17EW-2001	●																
		PKM35-4A0	●			●	●		●	●	●	●	●	●	●	●	●	●	
		PKM11-4A0	●			●	●		●	●	●	●	●	●	●	●	●	●	
		PKM13EPY-4002	●	●		●	●			●	●	●	●	●	●	●	●	●	●
		PKM17EPP-2002	●			●	●			●	●	●	●	●	●	●	●	●	●
		PKM17EPP-4001	●			●	●			●	●	●	●	●	●	●	●	●	●
		PKM22EPP-2001	●			●	●			●	●	●	●	●	●	●	●	●	●
		PKM22EPP-4001	●			●	●			●	●	●	●	●	●	●	●	●	●
		PKM22EPP-4005	●			●	●			●	●	●	●	●	●	●	●	●	●
		PKM22EPP-4007	●			●	●			●	●	●	●	●	●	●	●	●	●
		PKM22EP-2001				●	●			●	●	●	●	●	●	●	●	●	●
		PKM17EPT-4001				●	●			●	●	●	●	●	●	●	●	●	●
		PKM22EPT-2001				●	●			●	●	●	●	●	●	●	●	●	●
		PKM22EPT-4001				●	●			●	●	●	●	●	●	●	●	●	●
PKM13EPY-4000-TF01	●	●		●	●			●	●	●	●	●	●	●	●	●	●		
PKMC16E-4000-TY	●				●			●	●	●	●	●	●	●	●	●	●		
Self drive type	PKM11-6A0	●			●	●		●	●	●	●	●	●	●	●	●	●		
	PKM25-6A0	●			●	●			●		●	●	●	●	●	●	●		
	PKM29-3A0						●		●										
	PKM24SP-3805	●					●		●						●	●	●		
	PKM30SPT-2001								●			●	●		●				
	PKM30SPT-2501								●			●	●		●				
Piezoelectric Buzzer	With Circuit	PKB24SW-3301	●			●			●		●	●	●		●	●	●		
		PKB6-5A0					●		●		●	●	●						
		PKB5-3A0						●		●		●	●	●					
		PKB24SPC-3601	●				●			●		●	●	●	●	●	●	●	
		PKB8-4A0	●					●		●		●	●	●	●	●	●	●	
		PKB30SPC-2001	●					●		●		●	●	●	●	●	●	●	
PKB30SPC-3001	●					●		●		●	●	●	●	●	●	●			
Speaker	VSB35EW-0701B	●							●										
	VSB50EW-0301B	●							●										

Fire Alarm, Burglar Alarm, Laundry Machine, Bath, Interphone, Chime, Pager, Back Buzzer, ME Instruments, Measuring Instruments, Vending Machine, Calculator, Automobile, Communication Radio, Hemodynamometer, Thermometer, Running meter, Facsimile, Audio timer, Automatic Controlling Devices.

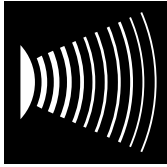

PIEZOELECTRIC DIAPHRAGM



Piezoelectric Diaphragm External Drive/Self Drive type

FEATURES

1. Very clear sound.
2. Ultra thin and light weight.
3. No contacts ; therefore, no noise and highly reliable.
4. Low power consumption for voltage type.

APPLICATIONS

Clocks/Pagers/Calculators/Washing machine/
Various alarms (Burglar alarms, etc.)

PART NUMBERING

(Please specify the part number when ordering.)

(Ex.)

7	N	B	-	31R2	-	19R7	D	M	-	1	C	A	0
①	②	③		④		⑤	⑥	⑦		⑧	⑨	⑩	⑪

- | | |
|---|--|
| <p>① Material of Piezoelectric Ceramic.</p> <p>② Material of Metal Plate.</p> <p>③ Sound Element, B : bender.</p> <p>④ Metal Plate Diameter.</p> <p>⑤ Dimensions of Piezoelectric Ceramic.</p> <p>⑥ Form of Piezoelectric Ceramic.</p> <p>⑦ Ni-electrode.</p> | <p>⑧ Oscillating Frequency by Measurement of Nodal Supporting.</p> <p>⑨ With Feedback Electrode.</p> <p>⑩ With Lead Wire.</p> <p>⑪ Other Specifications.</p> <p>• ⑤⑥⑦ is omitted for silver electrode.</p> |
|---|--|

DIMENSIONS

- Flat plate type

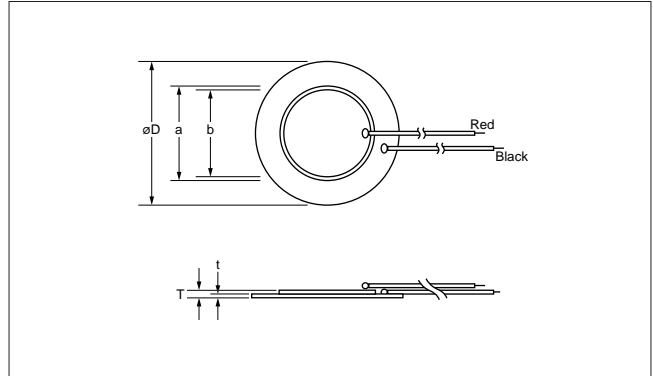

EXTERNAL DRIVE TYPE SPECIFICATIONS

Part Number	EIAJ Part Number	Characteristics			Dimensions (mm)					Packaging Quantity (pcs.)	Remarks	
		Resonant Freq. (kHz)	Resonant (Ω) Impedance	Capacitance (nF)	øD	a	b	T	t			
7BB-12-9	PD-SU2-C12-90	9.0±1.0	≤1000	8±30%	12.0	9.0	8.0	0.22	0.10	5120	Brass Plate	
7BB-15-6	PD-SU2-C15-60	6.0±1.0	≤ 350	10±30%	15.0	10.0	9.0	0.22	0.10	8000		
7BB-20-3	PD-SU2-C20-36	3.6±0.6	≤ 500	20±30%	20.0	14.0	12.8	0.22	0.10	3000		
7BB-20-6	PD-SU2-C20-63	6.3±0.6	≤ 300	10±30%	20.0	14.0	12.8	0.42	0.20	1800		
7BB-27-3	PD-SU2-C27-36	3.6±0.6	≤ 600	10±30%	27.0	14.0	12.8	0.52	0.30	1500		
7BB-27-3R5	PD-SU2-C27-30	3.0±0.6	≤ 300	26±30%	27.0	19.7	18.2	0.32	0.15	600		
7BB-27-4	PD-SU2-C27-46	4.6±0.5	≤ 200	20±30%	27.0	19.7	18.2	0.54	0.30	1500		
7BB-35-3	PD-SU2-C35-28	2.8±0.5	≤ 200	30±30%	35.0	25.0	23.0	0.53	0.30	800		
7BB-41-2	PD-SU2-C41-22	2.2±0.3	≤ 250	30±30%	41.0	25.0	23.0	0.63	0.40	400		
7BB-50M-1	PD-SU2-C50-10	1.0±0.3	≤1200	28±30%	50.0	25.0	23.0	0.44	0.20	600		Nickel-Plated Brass Plate
7SB-20-7	PD-SU2-C20-72	7.2±0.8	≤ 350	10±30%	20.0	14.0	12.8	0.42	0.20	1800		Stainless Plate
7MB-15-11	PD-SU2-C15-B0	11.0±3.0	≤ 400	5±30%	15.0	10.0	9.0	0.42	0.20	2400		Nickel Plated Iron
7MB-20-7	PD-SU2-C20-72	7.2±1.0	≤ 350	10±30%	20.0	14.0	12.8	0.42	0.20	1600		
7MB-27-3	PD-SU2-C27-34	3.4±0.5	≤ 500	10±30%	27.0	14.0	12.8	0.42	0.20	1800		
7MB-27-4	PD-SU2-C27-46	4.6±0.6	≤ 300	18±30%	27.0	19.7	18.2	0.44	0.20	1800	Iron Nickel Alloy Plate	
7NB-31R2-19R7DM-1	PD-SU2-C31-13	1.3±0.5	≤ 500	40±30%	31.2	19.7	18.2	0.22	0.10	1600		
7BB-20-6A0	PD-SU2-C20-63	6.3±0.6	≤ 550	10±30%	20.0	19.7	12.8	0.42	0.20	600		
7BB-27-4A0	PD-SU2-C27-46	4.6±0.5	≤ 200	20±30%	27.0	19.7	18.2	0.54	0.30	600	•With lead wire AWG32 Length : 50±5 Strip : 5±2 (in mm)	
7BB-35-3A0	PD-SU2-C35-28	2.8±0.5	≤ 200	30±30%	35.0	25.0	23.0	0.53	0.30	400		
7BB-41-2A0	PD-SU2-C41-22	2.2±0.3	≤ 300	30±30%	41.0	25.0	23.0	0.63	0.40	250		
7SB-20-7A1	PD-SU2-C20-72	7.2±0.8	≤ 350	10±30%	20.0	14.0	12.8	0.42	0.20	1600	With solder dot	

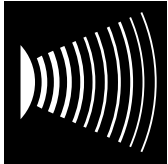

PIEZOELECTRIC DIAPHRAGM



Piezoelectric Diaphragm External Drive/Self Drive type

■ DIMENSIONS

● Flat plate type

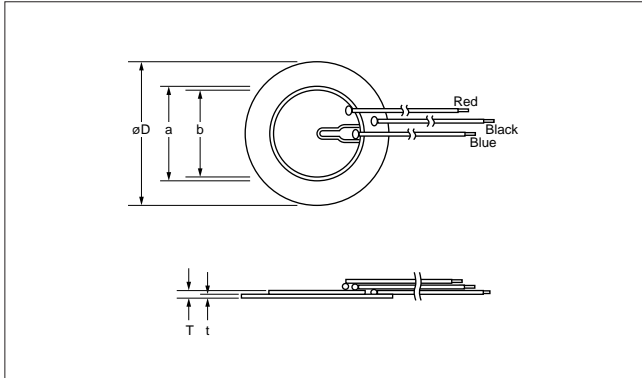

■ NODE DIAMETER

Part Number	Node Diameter (mm)
7BB-20-6C	ø13.5
7BB-27-4C	ø17.5
7BB-35-3C	ø22.5
7BB-41-2C	ø26.5

● Sound diaphragm without feedback electrode also have the same node diameters.

■ NOTICE

- 1. LSI protection**
 Protect LSI by using a varistor or zener diode.
 External heat or mechanical shock makes piezoelectric sounder to generate several 10Vp-p voltage.
- 2. Migration prevention**
 If DC voltage is applied to a piezoelectric sounder, silver migration may occur. Please pay full attention not to subject piezoelectric sounder to DC voltage for long periods.
- 3. Mounting method**
 Since the mounting method deeply influences the resonant frequency and sound pressure level, the most suitable mounting method should be determined according to the acoustic and electrical requirements.
- 4. Connecting to ICs.**
 - (1) When capacitors or resistors are used to change the phoning frequency, the timbre may be distorted. (See Fig. 1)
 - (2) Various types of Ringer ICs are made by various manufacturers. Please refer to us or the IC manufacturer for IC application.
 - (3) When distortion, as on (1) above, has occurred, a resistor should be used as shown in Fig. 2. A suitable resistance value should be chosen, preferably 1kΩ - 2kΩ. Instead of this is measure, a diode may also be applied as shown in Fig. 3.

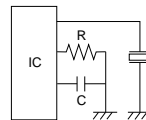

Fig.1

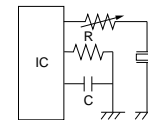

Fig.2

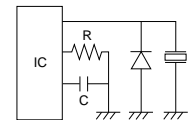
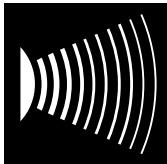

Fig.3

■ SELF DRIVE TYPE SPECIFICATIONS

Part Number	EIAJ Part Number	Characteristics			Dimensions (mm)					Packaging Quantity (pcs.)	Remarks
		Resonant Freq. (kHz)	Resonant (Ω) Impedance	Capacitance (nF)	øD	a	b	T	t		
7BB-20-6C	PD-SU3-C20-63	6.3±0.6	≤500	8.5±30%	20.0	14.0	12.8	0.42	0.20	1800	Brass Plate
7BB-27-3C	PD-SU3-C27-30	3.0±0.5	≤300	35±30%	27.0	19.7	18.2	0.27	0.15	2400	
7BB-27-4C	PD-SU3-C27-46	4.6±0.5	≤200	18±30%	27.0	19.7	18.2	0.54	0.30	1500	
7BB-35-3C	PD-SU3-C35-28	2.8±0.5	≤200	24±30%	35.0	25.0	23.0	0.53	0.30	800	
7BB-41-2C	PD-SU3-C41-22	2.2±0.3	≤250	24±30%	41.0	25.0	23.0	0.63	0.40	600	
7SB-34R7-3C	PD-SU3-C35-31	3.1±0.3	≤150	24±30%	34.7	25.0	23.4	0.50	0.25	1600	Stainless Plate
7NB-27-2C	PD-SU3-C27-22	2.2±0.5	≤300	27±30%	27.0	19.7	18.2	0.22	0.10	3000	Iron Nickel Alloy Plate
7NB-27-3C	PD-SU3-C27-30	3.0±0.5	≤300	24±30%	27.0	19.7	18.2	0.32	0.15	3000	
7NB-27-4C	PD-SU3-C27-38	3.8±0.5	≤300	19±30%	27.0	19.7	18.2	0.42	0.20	3000	
7BB-20-6CA0	PD-SU3-C20-63	6.3±0.6	≤800	8.5±30%	20.0	14.0	12.8	0.42	0.20	600	●With lead wire AWG32 Length : 50±5 Strip : 5±2 (in mm)
7BB-27-4CA0	PD-SU3-C27-46	4.6±0.5	≤200	18±30%	27.0	19.7	18.2	0.54	0.30	600	
7BB-35-3CA0	PD-SU3-C35-28	2.8±0.5	≤200	24±30%	35.0	25.0	23.0	0.53	0.30	400	
7BB-41-2CA0	PD-SU3-C41-22	2.2±0.3	≤350	24±30%	41.0	25.0	23.0	0.63	0.40	250	



PIEZOELECTRIC SOUNDER



Piezoelectric Sounder External Drive type

Now, microcomputers are widely used for microwave ovens, air conditioners, cars, toys, timers, and other alarm equipment. Externally driven piezoelectric sounders are used in digital watches, electronic calculators, telephones and other equipment. They are driven by a signal (ex, 2048Hz or 4096Hz) from an LSI and provide melodious sound.

FEATURES

1. Low power consumption.
2. No contacts ; therefore, no noise and highly reliable.

APPLICATIONS

- Telephone ringers.
- Various office equipment such as PPCs, printers and keyboards.
- Various home appliances such as microwave ovens.
- Confirmation sound of various audio equipment.

CIRCUIT

The following are examples of externally driven circuits.

- (1) Unstable multi-vibrator using Tr.
- (2) Circuits using inverters or NAND gates.

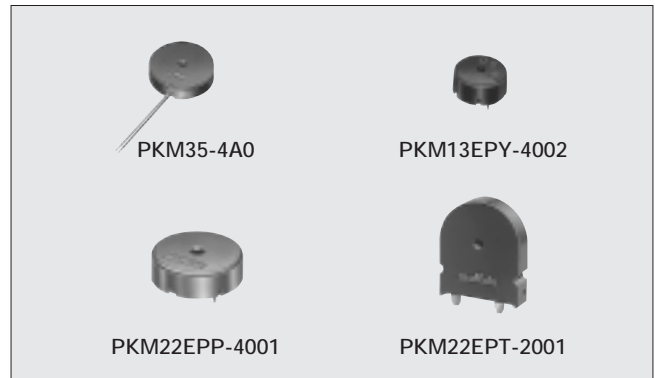
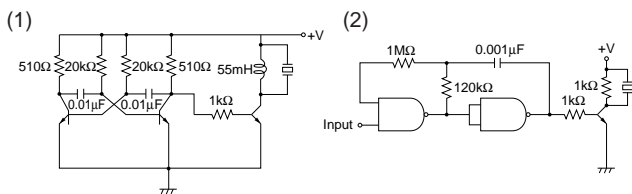

NOTICE

1. LSI protection
Protect LSI by using a varistor or zener diode. External heat or mechanical shock makes piezoelectric sounder to generate several 10Vp-p voltage.

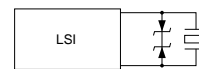

2. Migration prevention
If DC voltage is applied to a piezoelectric sounder, silver migration may occur. Please pay full attention not to subject piezoelectric sounder to DC voltage for long periods.
3. Sound pressure test
Test the sound pressure level on an actual condition. The frequency response depends on acoustic impedance of the surroundings.

SPECIFICATIONS

Lead Wire Type

Part Number	EIAJ Part Number	Sound Pressure Level [dB] (3Vp-p Square wave 10cm)	Sound Pressure Level [dB] (1Vrms sine wave 10cm) (Ref. only)	Capacitance [nF]	Max. Input Voltage [Vp-p]	Operating Temp. Range [°C]	Storage Temp. Range [°C]	Packaging Quantity [pcs]
PKM17EW-2001	PS-RW2-C17-20	72 min. (2kHz)	70 min. (2kHz)	40±30% (120Hz)	7	-20 to +70	-30 to +80	250
PKM35-4A0	PS-RW2-C17-40	75 min. (4kHz)	70 min. (4kHz)	9.5±30% (1kHz)	25			500
PKM11-4A0	PS-RW2-C24-40	75 min. (4kHz)	75 min. (4kHz)	10±30% (1kHz)	25			400

Pin Type

Part Number	EIAJ Part Number	Sound Pressure Level [dB] (3Vp-p Square wave 10cm)	Sound Pressure Level [dB] (1Vrms sine wave 10cm) (Ref. only)	Capacitance [nF]	Max. Input Voltage [Vp-p]	Operating Temp. Range [°C]	Storage Temp. Range [°C]	Packaging Quantity [pcs]
PKM13EPY-4002	PS-RP2-C13-40	70 min. (4kHz)	70 min. (4kHz)	5.5±30% (1kHz)	25	-20 to +70	-30 to +80	330
PKM17EPP-2002	PS-RP2-C17-20	70 min. (2kHz)	70 min. (2kHz)	34±35% (120Hz)	25 (with polarity)			200
PKM17EPP-4001	PS-RP2-C17-40	72 min. (4kHz)	72 min. (4kHz)	7±30% (1kHz)	25			200
PKM22EPP-2001	PS-RP2-C22-20	70 min. (2kHz)	70 min. (2kHz)	19±30% (120Hz)	25			750
PKM22EPP-4001	PS-RP2-C22-40	75 min. (4kHz)	75 min. (4kHz)	12±30% (1kHz)	25			900
PKM22EPP-4005	PS-RP2-C22-40	75 min. (4kHz)	75 min. (4kHz)	12±30% (1kHz)	25			750
PKM22EPP-4007	PS-RP2-C22-40	85 min. (4kHz)	85 min. (4kHz)	12±30% (1kHz)	25			750
PKM22EP-2001	PS-RP2-C22-20	75 min. (2kHz)	75 min. (2kHz)	17±30% (120Hz)	25			360
PKM17EPT-4001	PS-RP2-V20-40	75 min. (4kHz)	75 min. (4kHz)	9.5±30% (1kHz)	25			180
PKM22EPT-2001	PS-RP2-V27-20	70 min. (2kHz)	70 min. (2kHz)	19±30% (120Hz)	25			300
PKM22EPT-4001	PS-RP2-V27-40	85 min. (4kHz)	85 min. (4kHz)	10±30% (1kHz)	25			300

■ DIMENSIONS

PKM17EW-2001

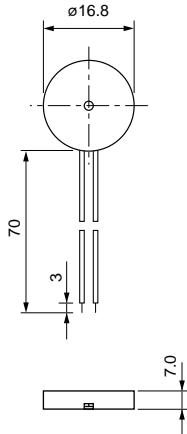

PKM35-4A0

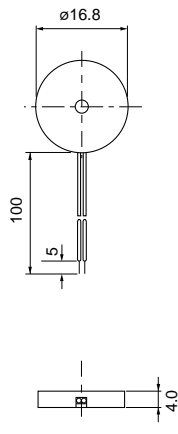

PKM11-4A0

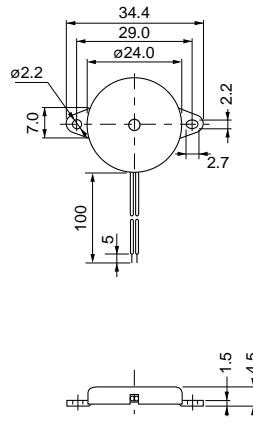

PKM13EPY-4002

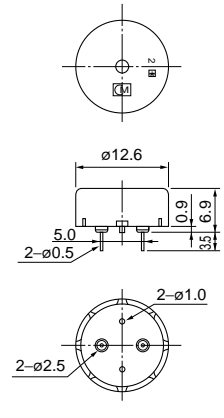

PKM17EPP-2002

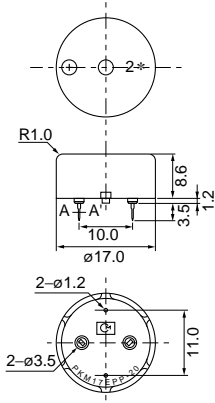

PKM17EPP-4001

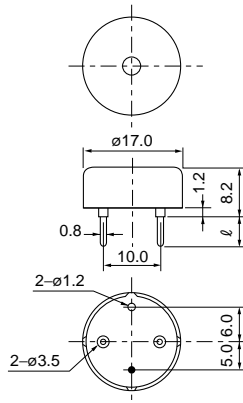

PKM22EPP-2001

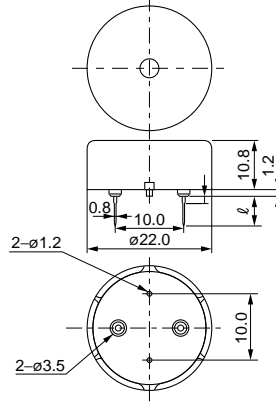

PKM22EPP-4001

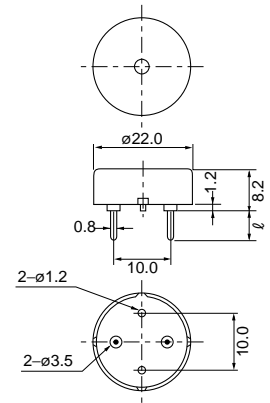

Part Number	ℓ (mm)
PKM17EPP-4001	6.5
PKM17EPP-4002	3.5

Part Number	ℓ (mm)
PKM22EPP-2001	6.5
PKM22EPP-2002	3.5

Part Number	ℓ (mm)
PKM22EPP-4001	6.5
PKM22EPP-4002	3.5

PKM22EPP-4005

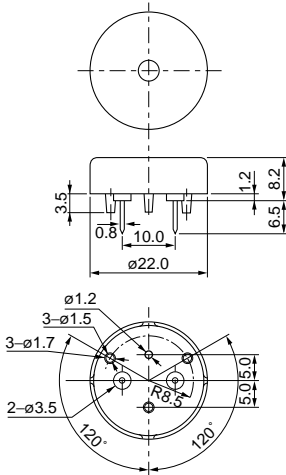

PKM22EPP-4007

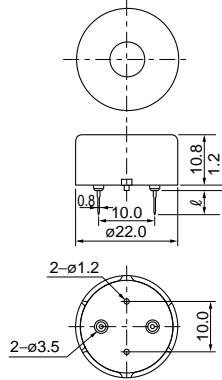

Part Number	ℓ (mm)
PKM22EPP-4007	6.5
PKM22EPP-4012	3.5

PKM22EP-2001

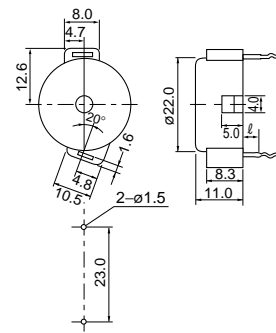

Part Number	ℓ (mm)
PKM22EP-2001	4.0
PKM22EP-2002	8.0
PKM22EP-2003	12.0

PKM17EPT-4001

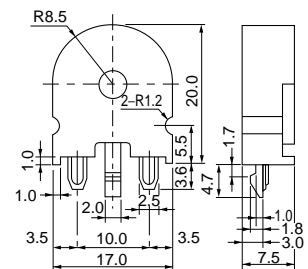

PKM22EPT-2001

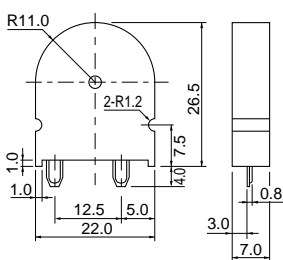

PKM22EPT-4001

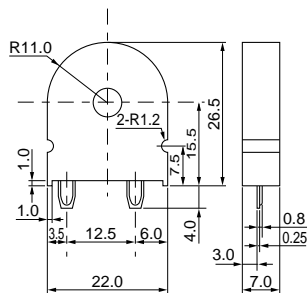

(in mm)

FREQUENCY RESPONSE

(Input Volt : Square Wave 3Vp-p)
(Measuring Distance : 10cm)

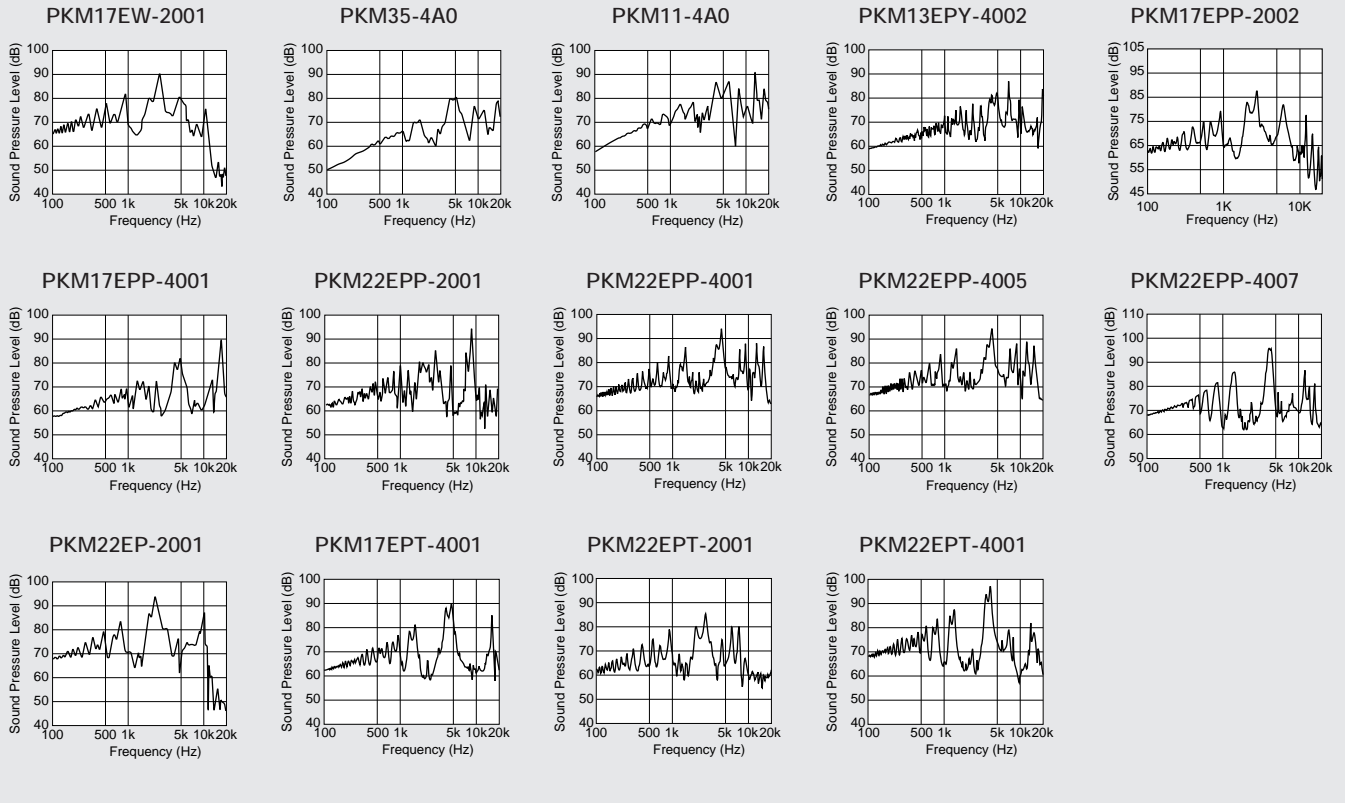

(Input Volt : Sine Wave 1Vrms)
(Measuring Distance : 10cm)

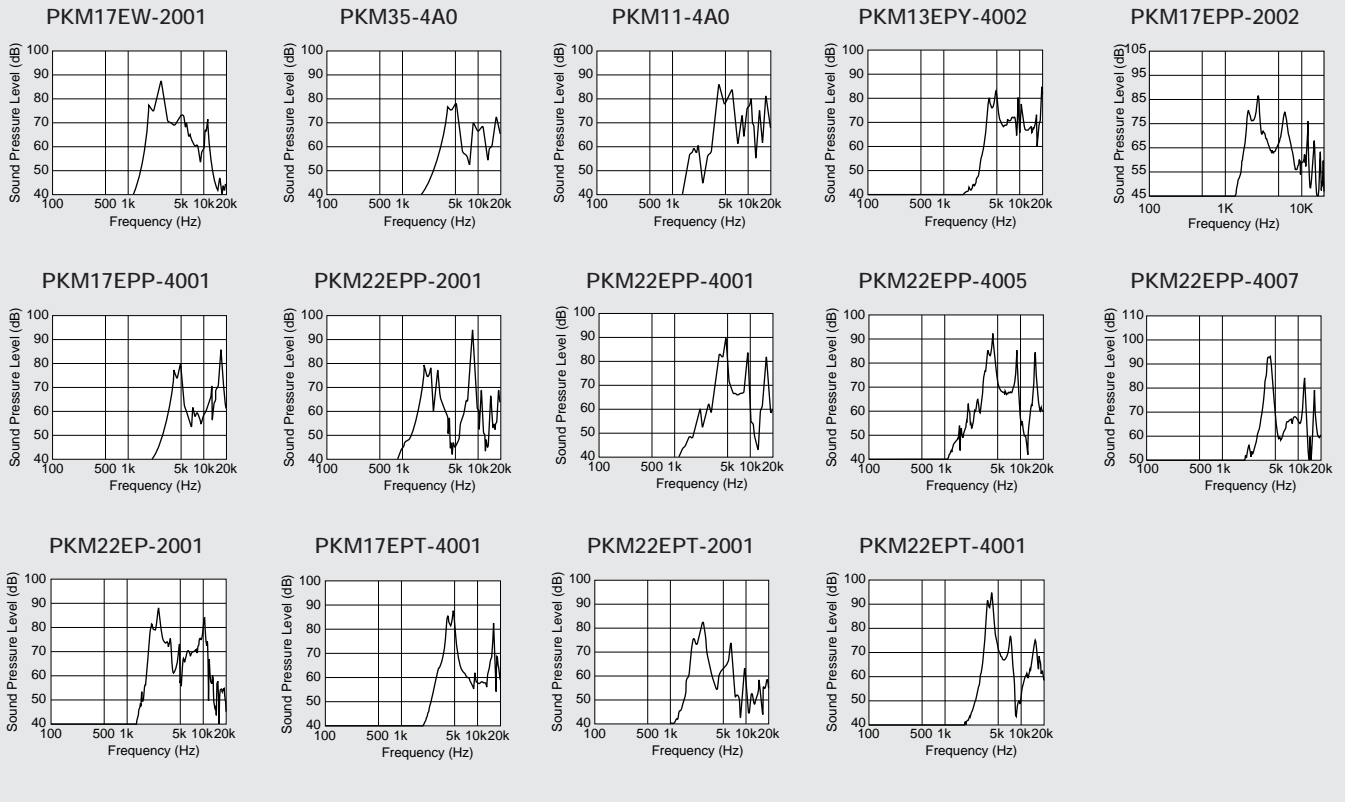

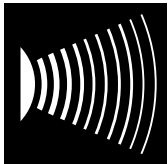

PIEZOELECTRIC SOUNDER



Taping Type Piezoelectric Sounder

Taking advantage of extensive automatic insertion designing technology and materials experience, Murata has developed standard taping type piezoelectric sounder. This Murata technology supports labor and cost saving activities.

FEATURES

1. High and stable mountability.
2. Flat packaging.
3. Minimum quantity (order in sets only) : 500 pcs

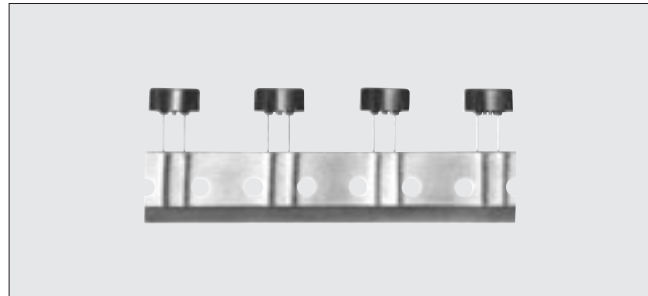

SPECIFICATIONS

Part Number	PKM13EPY-4000-TF01
Sound Pressure Level (3Vp-p Square wave 10cm)	70dB min. (4kHz)
Capacitance	5.5nF±30% (1kHz)
Max. Input Voltage	25Vp-p
Operating Temp. Range	-20°C to +70°C
Storage Temp. Range	-30°C to +80°C
Packaging Quantity	500 pcs/1 pack

FREQUENCY RESPONSE

Input Volt : Square Wave 3Vp-p Measuring Distance : 10cm

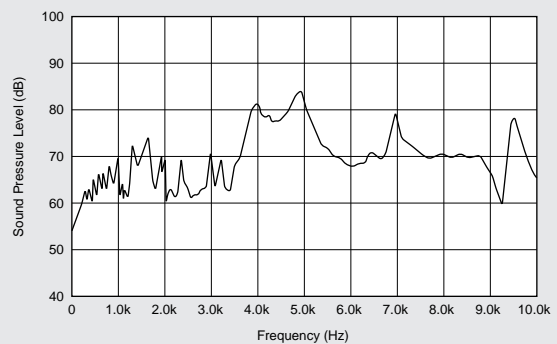

DIMENSIONS

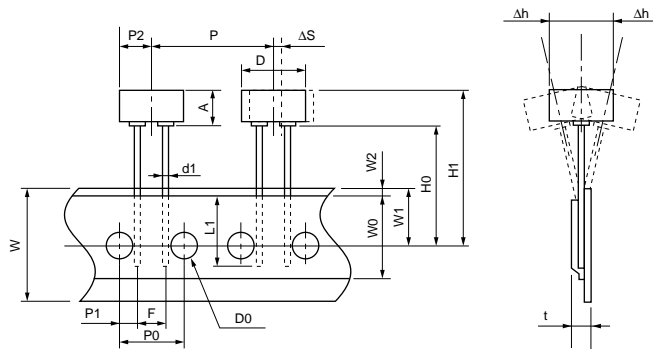

(in mm)

Item	Code	Nominal Value	Tol.	Remarks
Width of Diameter	D	ø12.6	±0.5	
Height of Resonator	A	6.9	±0.5	
Dimensions of Terminal	d1	ø0.5	±0.1	
Lead length Under The Hold down Tape	L1	8.0 min.	—	
Pitch of Component	P	25.4	±0.5	
Pitch of Sprocket	P0	12.7	±0.2	Tolerance for Pitches 10×P0=127±2mm
Length from Hole Center to Lead	P1	3.85	±0.7	
Length from Hole Center to Component Center	P2	6.35	±0.7	
Lead Spacing	F	5.0	±0.5	
Slant to The Forward or Backward	Δh	0	±1.0	360°: 1mm max.
Width of Carrier Tape	W	18.0	±0.5	
Width of Hold down Tape	W0	12.5 min.	—	Hold down tape does not exceed the carrier tape
Position of Sprocket Hole	W1	9.0	±0.5	
Gap of Hold Down Tape and Carrier Tape	W2	2.0 max.	—	
Distance Between The Center of Sprocket Hole and Lead Stopper	H0	18.0	±0.5	
Total Height of Resonator	H1	26.0 max.	—	
Diameter of Sprocket Hole	D0	ø4.0	±0.2	
Total Thickness of Tape	t	0.6	±0.2	
Body Tilt	ΔS	0	±1.0	

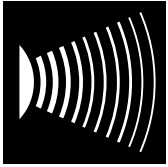

PIEZOELECTRIC SOUNDER



SMD Piezoelectric Sounder

Taking advantage of extensive acoustic and mechanical designing technology and high performance ceramics, Murata has developed SMD piezoelectric sounder that suites thin, high-density design of electronic equipment.

FEATURES

1. High S.P.L. and clear sound.
2. Reflowable.
3. Tray packaging.
3. Minimum quantity (order in sets only) : 80 pcs

SPECIFICATIONS

Part Number	PKMC16E-4000-TY
Sound Pressure Level (3Vp-p Square wave 10cm)	75dB min. (4kHz)
Capacitance	14nF±30% (1kHz)
Max. Input Voltage	25Vp-p
Operating Temp. Range	-20°C to +70°C
Storage Temp. Range	-30°C to +80°C

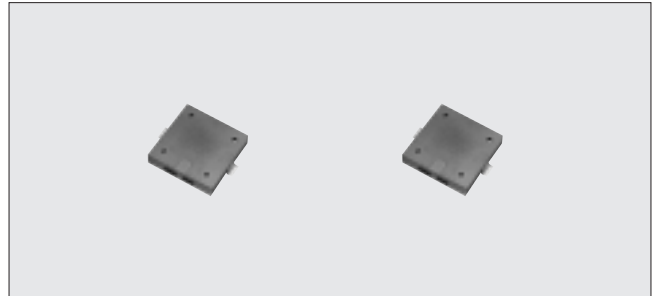

FREQUENCY RESPONSE

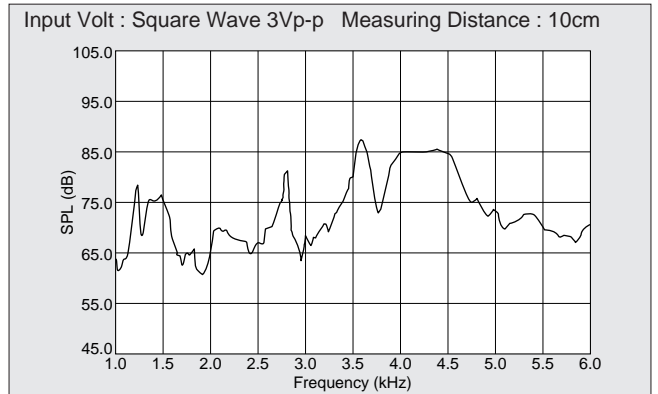

DIMENSIONS

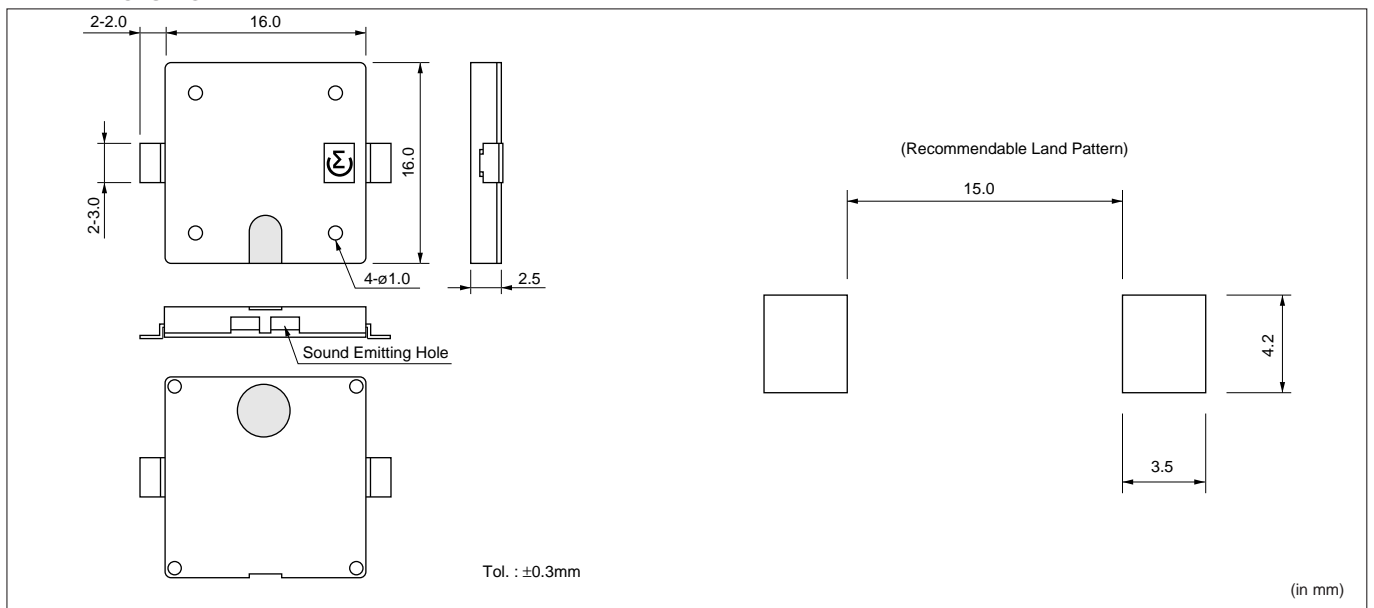

■ FREQUENCY RESPONSE

(Input Volt : Square Wave 30Vp-p)
(Measuring Distance : 1m)

PKM34EW-1101/1201C

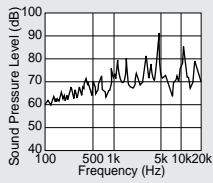

PKM44EW-1001C

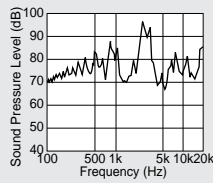

PKM44EP-0901

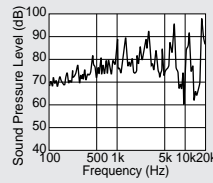

PKM33EP-1201C

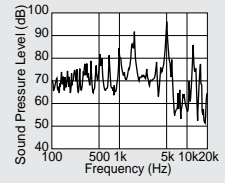

(Input Volt : Sine Wave 1Vrms)
(Measuring Distance : 10cm)

PKM34EW-1101/1201C

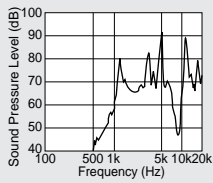

PKM44EW-1001C

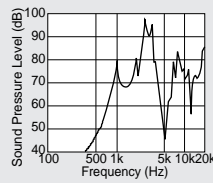

PKM44EP-0901

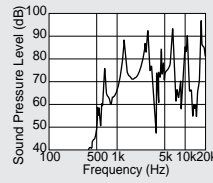

PKM33EP-1201C

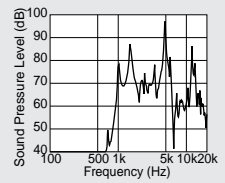

■ NOTICE

1. LSI protection

Protect LSI by using a varistor or zener diode.
External heat or mechanical shock makes piezoelectric sounder to generate several 10Vp-p voltage.

2. Migration prevention

If DC voltage is applied to a piezoelectric sounder, silver migration may occur. Please pay full attention not to subject piezoelectric sounder to DC voltage for long periods.

3. Mounting method

Since the mounting method deeply influences the resonant frequency and sound pressure level, the most suitable mounting method should be determined according to the acoustic and electrical requirements.

4. Connecting to ICs.

- (1) When capacitors or resistors are used to change the phoning frequency, the timbre may be distorted. (See Fig. 1)
- (2) Various types of Ringer ICs are made by various manufacturers. Please refer to us or the IC manufacturer for IC application.
- (3) When distortion, as on (1) above, has occurred, a resistor should be used as shown in Fig. 2. A suitable resistance value should be chosen, preferably 1kΩ - 2kΩ. Instead of this is measure, a diode may also be applied as shown in Fig. 3.

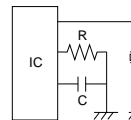

Fig.1

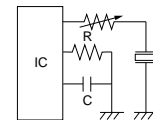

Fig.2

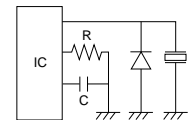
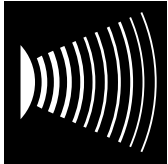

Fig.3



PIEZOELECTRIC SOUNDER

Piezoelectric Sounder Self Drive Type

Piezoelectric sounder self drive type requires only simple circuit and Dc power supply. Since this type uses resonant system, it is also available for alarms which need large sound volume.

APPLICATIONS

- Gas alarms, burglar alarms, smoke detectors.
- Air conditioners, Microwave ovens, washing machines and other home-electronic appliance controlled by microcomputer.
- Toys, game machines.

CIRCUITS

The standard self-driven circuits utilizes transistor switching. The circuit constants shown in the table below are optimally chosen to maintain stable oscillation. So please follow it when you design a circuit.



NOTICE

Please pay attention to following points in order piezoelectric sounder to maintain stable oscillation.

1. Be sure to use a low impedance type power supply.
2. Do not cover the hole with tape or other obstacle.
3. There should not be any obstacle within 15mm from the top of sounder.

SPECIFICATIONS

Lead Wire Type

Part Number	EIAJ Part Number	Sound Pressure Level [dB] (12Vdc, 10cm)	Oscillating Frequency [kHz]	Current Consumption [mA]	Operating Voltage Range [Vdc]	Operating Temp. Range [°C]	Storage Temp. Range [°C]	Packaging Quantity [pcs]
PKM11-6A0	PS-RW3-C24-65	80 min.	6.5±0.7	8 max.	3.0 to 20.0	-20 to +70	-30 to +80	400

Pin Type

Part Number	EIAJ Part Number	Sound Pressure Level [dB] (12Vdc, 10cm)	Oscillating Frequency [kHz]	Current Consumption [mA]	Operating Voltage Range [Vdc]	Operating Temp. Range [°C]	Storage Temp. Range [°C]	Packaging Quantity [pcs]
PKM25-6A0	PS-RP3-C25-68	90 min.	6.8±0.7	10 max.	3.0 to 20.0	-20 to +70	-30 to +80	630
PKM29-3A0	PS-RP3-C39-34	105 min. (9Vdc)	3.4±0.4	20 max.	4.5 to 18.0			90
PKM24SP-3805	PS-RP3-C24-38	90 min.	3.8±0.4	12 max.	3.0 to 20.0			360
PKM30SPT-2001	PS-RP3-V33-20	75 min.	2.0±0.3	20 max.				70
PKM30SPT-2501	PS-RP3-V33-25	80 min.	2.5±0.3	20 max.				

■ DIMENSIONS

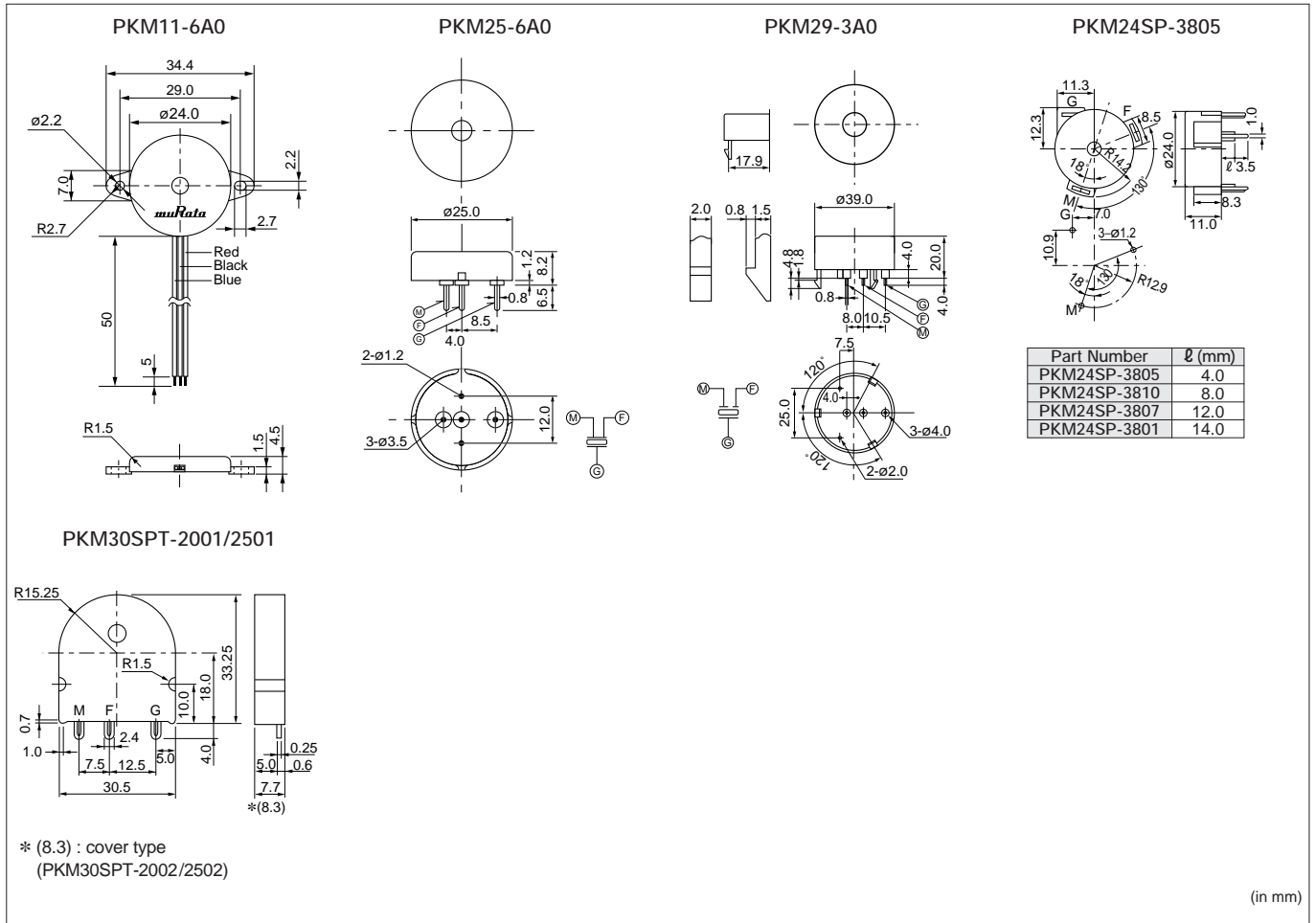

■ STANDARD CIRCUIT EXAMPLES

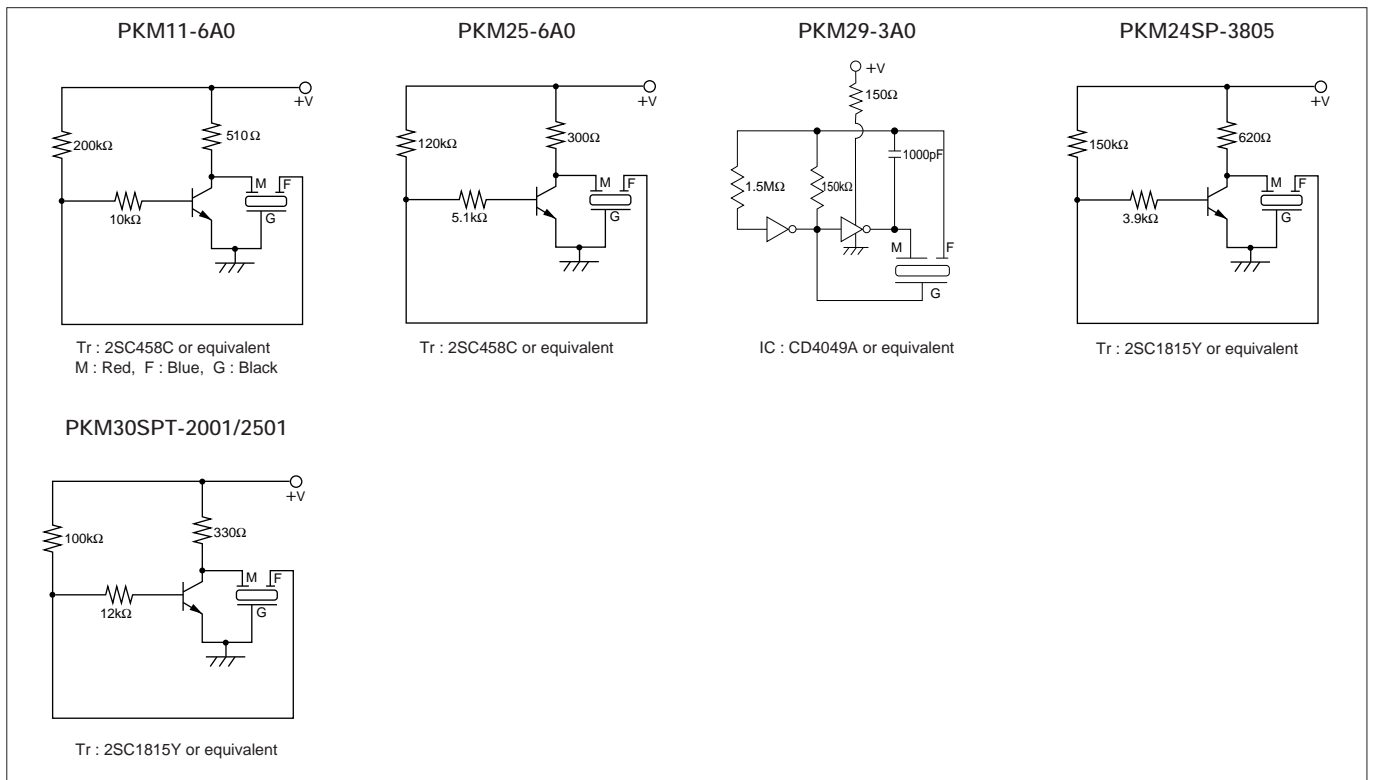

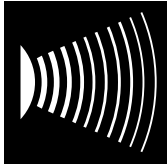

PIEZOELECTRIC BUZZER



Piezoelectric Buzzer

This is unified piezoelectric sounder which has piezoelectric diaphragm of 3 terminals connected to self drive circuit, and it easily generates sound with only a DC power supply (3.0-20Vdc). Using suitably designed resonant system, this type can be used where large sound volumes are needed.

APPLICATIONS

- Gas alarms, burglar alarms.
- Air conditioners, microwave ovens and various types of microcomputer controlled home-electronic appliances.
- Automobile speed alarms, navigators, car stereos and other automobile equipment.
- Toys, games, and other simple electronic devices such as teaching aids.

CIRCUITS

This type of piezoelectric buzzer is built in complete circuit ; so there is no need for another circuit for generating sound. Resistors should not be connected in series to the power supply as this will produce irregular oscillation. When resistor is necessary to control sound volume, use capacitor (1μF) parallel with the buzzer together.

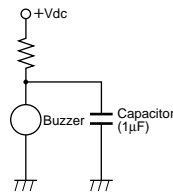

NOTICE

- Please pay attention to following points in order piezoelectric sounder to maintain stable oscillation.
- (1) Do not cover the hole with tape or other obstacles.
 - (2) There should not be any obstacle within 15mm from top of buzzer.
 - (3) Please use these piezoelectric buzzer within the limit of rated voltage. Consult us if higher voltage type is required.

SPECIFICATIONS

Lead Wire Type

Part Number	EIAJ Part Number	Sound Pressure Level [dB] (12Vdc, 10cm)	Oscillating Frequency [kHz]	Current Consumption [mA]	Operating Voltage Range [Vdc]	Operating Temp. Range [°C]	Storage Temp. Range [°C]	Packaging Quantity [pcs]
PKB24SW-3301	PB-RWD-C24-33	80 min.	3.3±0.5	12 max.	3.0 to 20.0	-20 to +70	-30 to +80	200
PKB6-5A0	PB-RWD-C34-47	95 min.	4.7±0.7					25
PKB5-3A0	PB-RWD-C42-28		2.8±0.5					

Pin Type

Part Number	EIAJ Part Number	Sound Pressure Level [dB] (12Vdc, 10cm)	Oscillating Frequency [kHz]	Current Consumption [mA]	Operating Voltage Range [Vdc]	Operating Temp. Range [°C]	Storage Temp. Range [°C]	Packaging Quantity [pcs]
PKB24SPC-3601	PB-RPD-C24-36	90 min.	3.6±0.5	16 max.	3.0 to 15.0	-20 to +70	-30 to +80	650
PKB8-4A0	PB-RPD-C24-38	95 min.	3.8±0.5	13 max.	3.0 to 20.0			90
PKB30SPC-2001	PB-RPD-C30-20	92 min.	2.0±0.4	15 max.	3.0 to 15.0			80
PKB30SPC-3001	PB-RPD-C30-27		2.7±0.4					

■ DIMENSIONS

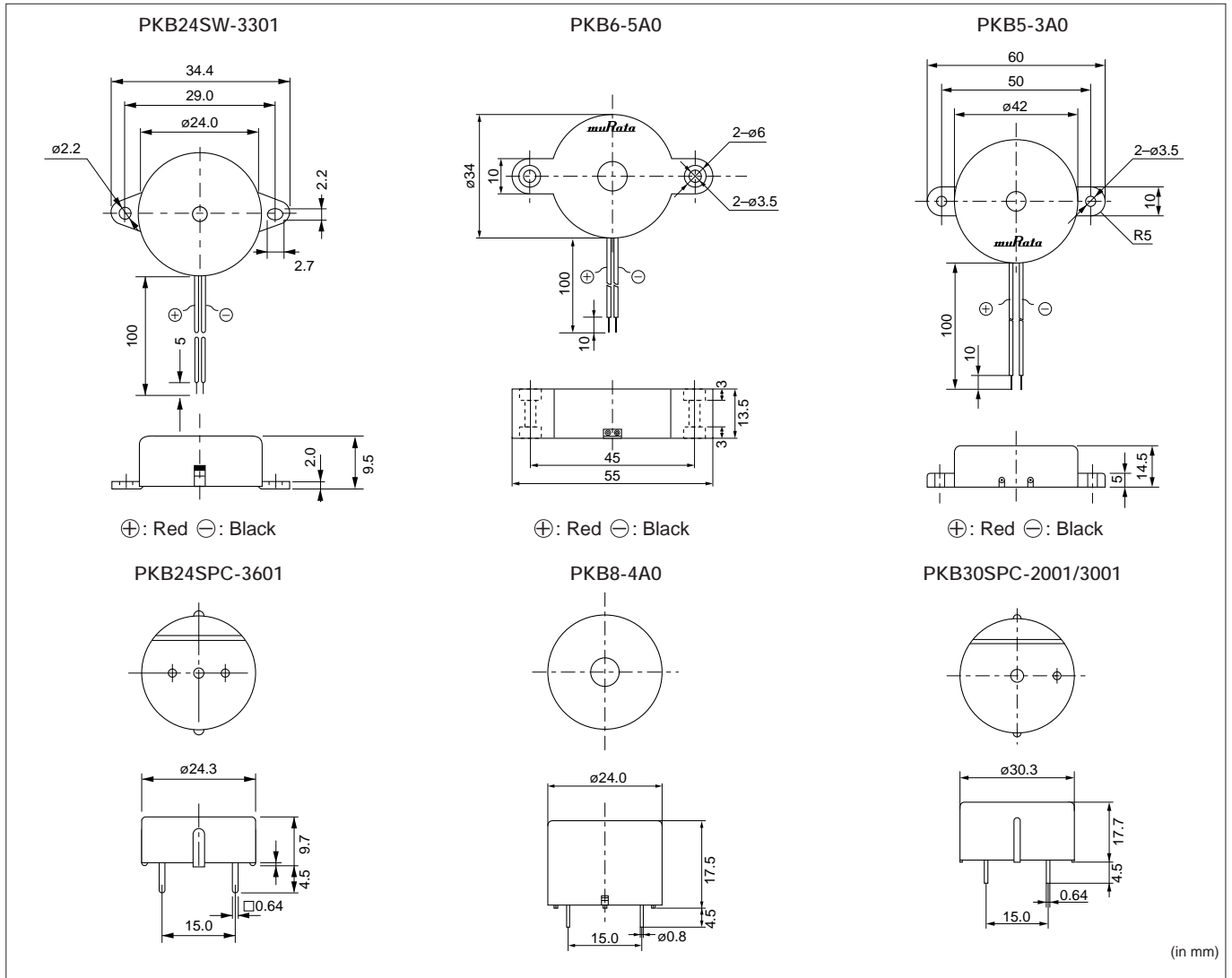

■ VOLTAGE:SOUND PRESSURE LEVEL / VOLTAGE:CURRENT CONSUMPTION CHARACTERISTICS (Measuring Distance : 10cm)

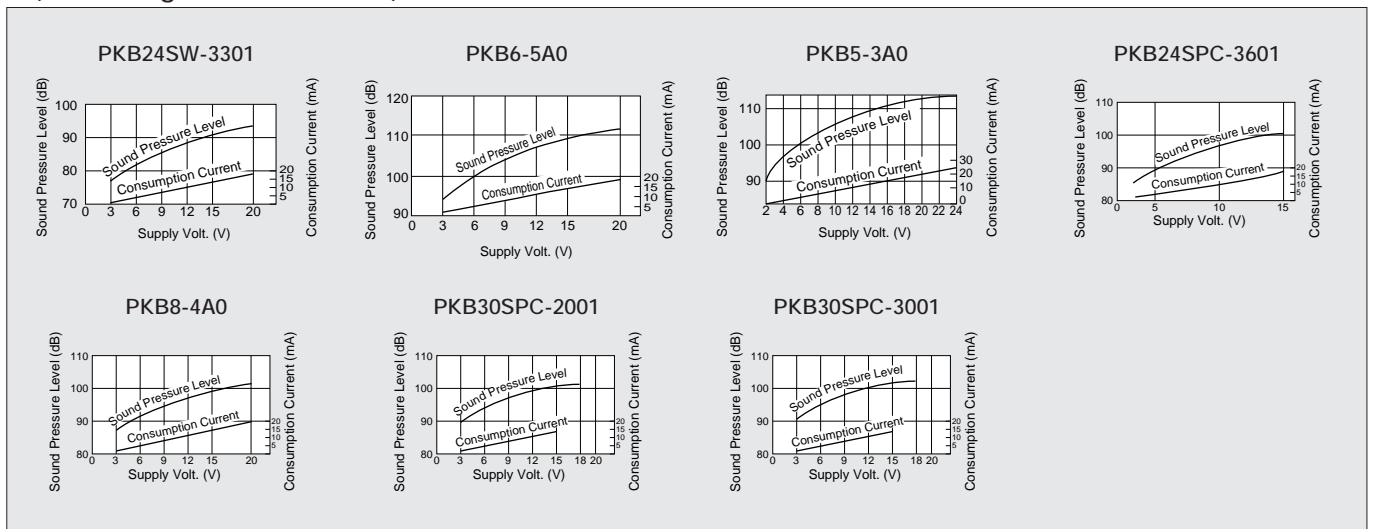

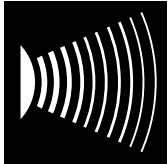

PIEZOELECTRIC SPEAKER



Piezoelectric Speaker (CERAMITONE®)

As voice synthesizing techniques with ICs and LSIs are rapidly progressed, human voice synthesizing devices are put into practical use for portable calculators, clocks, vending machines, translating machines and so forth. In order to meet the demand, Murata has developed Piezoelectric Speaker best suited for making synthesized voice or melody.

FEATURES

1. High efficiency compared with conventional electromagnetic type speakers.
2. Ultra-thin and light-weight.
3. High impedance with less power consumption.
4. No electric noise, because they have no mechanical contacts.
5. Direct drive by IC is available.

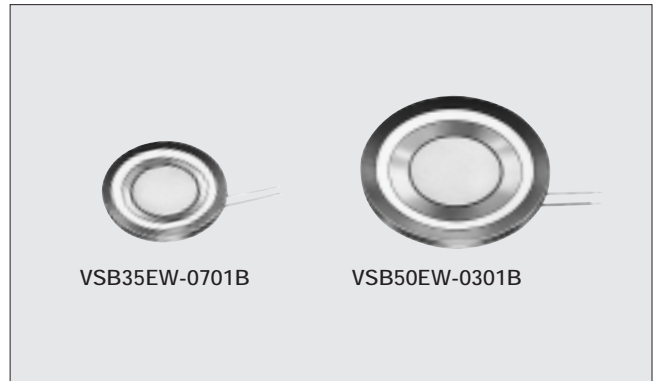

NOTICE

1. Please pay full attention not to subject piezoelectric sounder to DC voltage for long periods.
2. Protect LSI by using a varistor or zener diode. External heat or mechanical shock makes piezoelectric sounder to generate several 10 Vp-p voltage.

SPECIFICATIONS

Part Number	Freq. Range [Hz]	Capacitance [nF] (120Hz)	Impedance [Ω] (1kHz)	Lowest Resonant Freq. [Hz]	Max. Input	Operating Temp. Range [°C]	Storage Temp. Range [°C]	Packaging Quantity [pcs]
VSB35EW-0701B	600 to 20k	340±35%	600	950	75mW	-20 to +70	-30 to +80	160
VSB50EW-0301B	250 to 20k	600±35%	300	400	150mW			80

DIMENSIONS

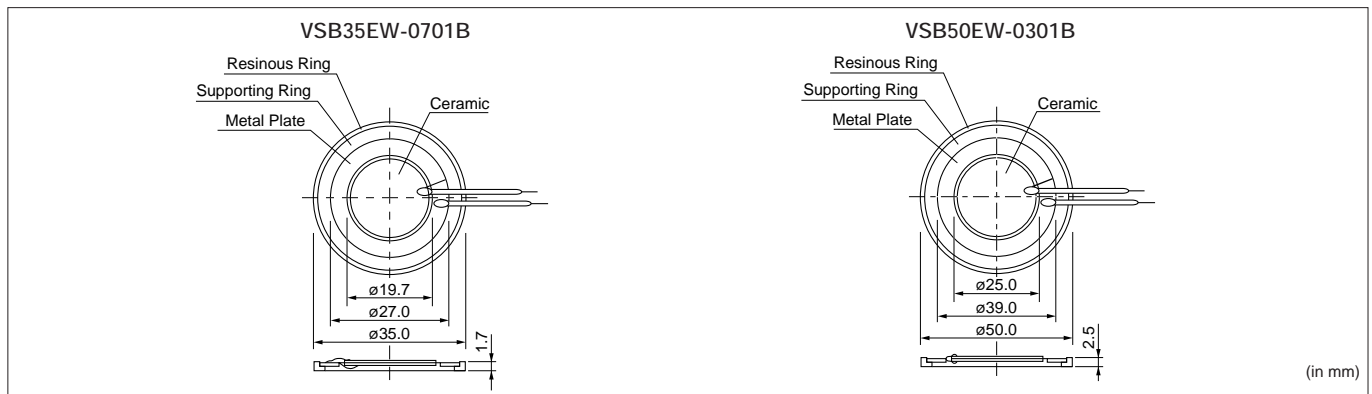

■FREQUENCY RESPONSE

(Input Volt : Sine Wave 1Vrms)
 (Measuring Distance : 10cm)

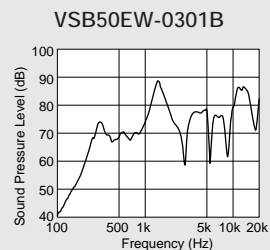
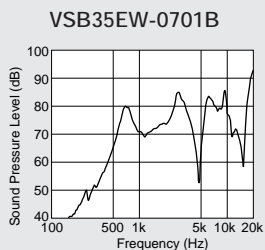

■IMPEDANCE / FREQUENCY CHARACTERISTICS

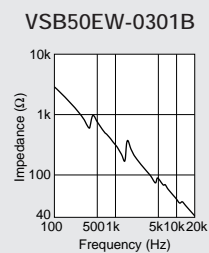
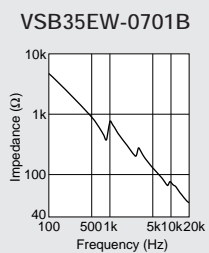

⚠ Note:**1. Export Control**

⟨For customers outside Japan⟩

Murata products should not be used or sold for use in the development, production, stockpiling or utilization of any conventional weapons or mass-destructive weapons (nuclear weapons, chemical or biological weapons, or missiles), or any other weapons.

⟨For customers in Japan⟩

For products which are controlled items subject to the "Foreign Exchange and Foreign Trade Law" of Japan, the export license specified by the law is required for export.

2. Please contact our sales representatives or product engineers before using our products listed in this catalog for the applications listed below which require especially high reliability for the prevention of defects which might directly cause damage to the third party's life, body or property, or when intending to use one of our products for other applications than specified in this catalog.

- ① Aircraft equipment
- ② Aerospace equipment
- ③ Undersea equipment
- ④ Power plant equipment
- ⑤ Medical equipment
- ⑥ Transportation equipment (vehicles, trains, ships, etc.)
- ⑦ Traffic signal equipment
- ⑧ Disaster prevention / crime prevention equipment
- ⑨ Data-processing equipment
- ⑩ Application of similar complexity and/or reliability requirements to the applications listed in the above

3. Product specifications in this catalog are as of February 2000. They are subject to change or our products in it may be discontinued without advance notice. Please check with our sales representatives or product engineers before your ordering. If there are any questions, please contact our sales representatives or product engineers.**4. The parts numbers and specifications listed in this catalog are for information only. You are requested to approve our product specification or to transact the approval sheet for product specification, before your ordering.****5. Please note that unless otherwise specified, we shall assume no responsibility whatsoever for any conflict or dispute that may occur in connection with the effect of our and/or third party's intellectual property rights and other related rights in consideration of your using our products and/or information described or contained in our catalogs. In this connection, no representation shall be made to the effect that any third parties are authorized to use the rights mentioned above under licenses without our consent.****6. None of ozone depleting substances (ODS) under the Montreal Protocol is used in manufacturing process of us.**